

NOTE: 1
DESIGN CODE:
N/A

NOTE: 2
TECHNICAL CLASSIFICATION:
Article Type: 003-Valve Stabs
Main Group: 3.04. Ø60-Valvestab
Intermediate Group: 3.34.02. Receptacle
Sub Group: 3.34.75.3. Triple

NOTE: 3
INTERFACE INFORMATION:
Pressure Rating Bar: 250
Material: Intervention
Weight: 10,7 kg
Volume: 2,22 dm³
Surface Area: 4653 cm²
Hydraulic: 2x3/4" BSP - 1x1/2" BSP
Mechanical: N/A
Electrical: N/A
Com. & Protocol: N/A

NOTE: 4
OPERATION & MAINTENANCE INFORMATION:
600134-TD-0004

NOTE: 5
ADDITIONAL INFORMATION:
TO BE PLUGGED WITH 3/8" BSP IF COMPENSATOR
PORTS ARE NOTE USED.

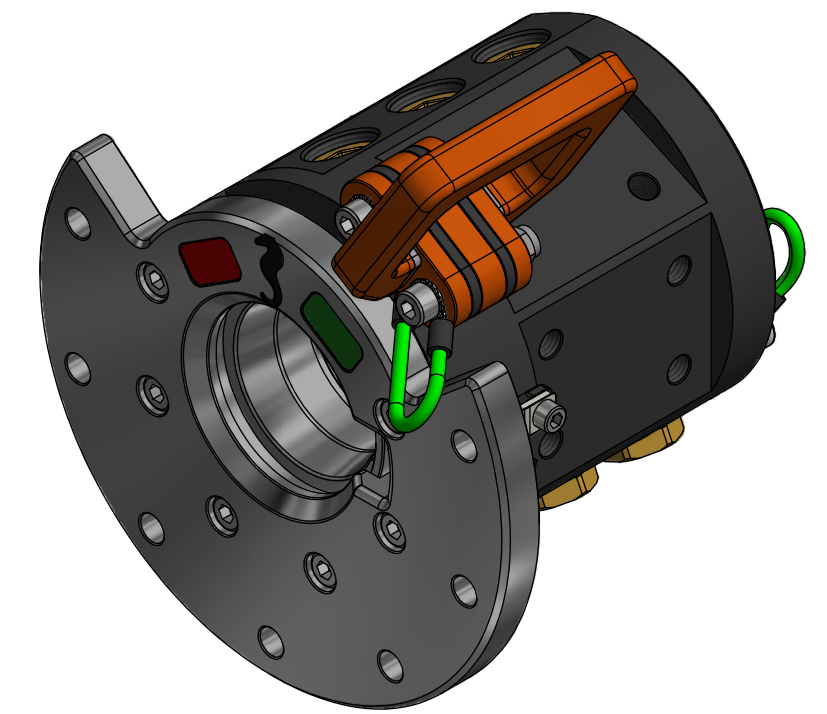

Rev.	Date	Reason for issue	Revision change	Made	Chk'd	Appr.
02	29.5.2024	7-IFC (Issued for Construction)		WTJ	HNJ	WTJ
01	15.2.2024	7-IFC (Issued for Construction)		HNJ	LGH	HNJ



Dwg Scale: NTS	Drawing title: Ø60 TP VStab Rec 250Bar Interv Man BSP 3/4-1/2 wComp. Ports Pan Mount
Dwg Proj: A3	
Dwg Format: A3	Drawing number: BC0814
	Rev 02